

NO	DESCRIPTION	MATERIAL	Q'TY
1	CONTAINER	TRANSPARENT SAN RESIN	1
2	COVER	ABS RESIN	1
3	VENT CAP	ABS WITH CERAMIC	1
4	TERMINAL	LEAD-ALLOY WITH BRASS	4
5	POLE	LEAD	4
6	NEGATIVE PLATE	LEAD-ANTIMONY ALLOY	13
7	SEPARATOR	SYNTHETIC RESIN	24
8	POSITIVE PLATE	LEAD-ANTIMONY ALLOY	12
9	SEDIMENT BRIDGE	SAN RESIN	1
10	RETAINER	SYNTHETIC RESIN	24

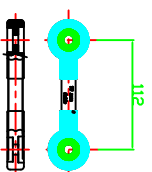
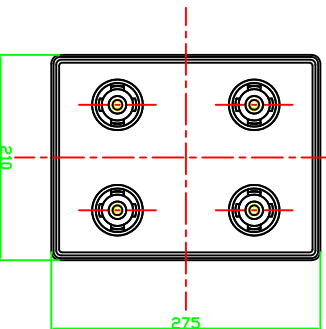
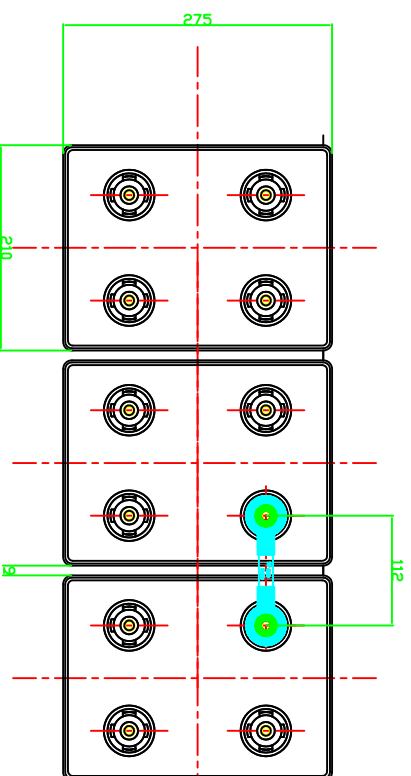
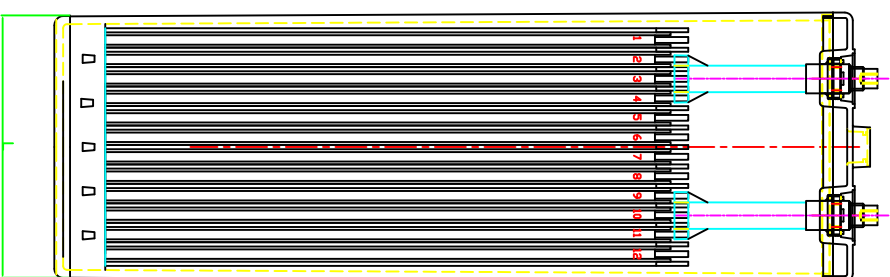
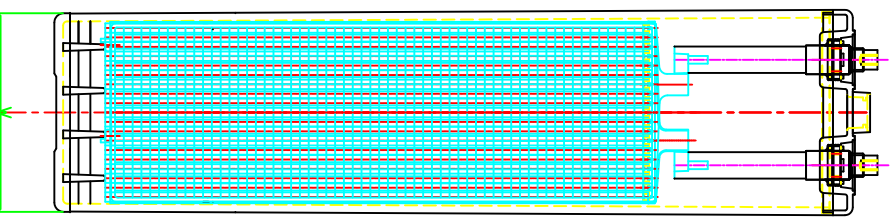

REQUESTED BY	DATE	MADE BY	REVISION	CHECKED BY	RELEASED BY

UKB CO., LTD. KOREA	
TITLE	DPZS1500 Construction-02
DESIGNED BY	SCALE 1 : 1
DRAWN BY YJP	DATE 1006.29
CHECKED BY	DATE
APPROVED BY	DATE
RELEASED BY	DATE
DRAWING AND PART NO.	